

225-6201 Mini-Sampler for Welding Aerosol

The Mini-Sampler* is designed for sampling of manganese in welding aerosol, to the requirements of the standard ISO 10882-1 "Health and safety in welding and allied processes - Sampling of airborne particles and gases in the operator's breathing zone - Part 1: Sampling of airborne particles". The Mini-Sampler can also be used for analysis of other chemicals in welding aerosol and gravimetric analysis of welding aerosol, but with reduced sampling efficiency for particle sizes above 20µm.

The performance of the Mini-Sampler is verified in the paper "A Headset-Mounted Mini Sampler for Measuring Exposure to Welding Aerosol in the Breathing Zone" by G. Lidén and J. Surakka, published in The Annals of Occupational Hygiene Vol. 53 No. 2. This paper is available for download at <http://annhyg.oxfordjournals.org/content/53/2/99.abstract>.

It is also highly recommended to obtain and read the standard ISO 10882-1 before carrying out any sampling using the Mini-Sampler.

When sampling for welding aerosol it is important to sample as close to the operator's nose and mouth as possible because of the steep concentration gradients that occur in the immediate vicinity of the plume of welding fumes. It is therefore essential to sample behind the welder's face shield, if worn, as it is the air in this region that is inhaled.

The Mini-Sampler is designed specifically for use with the SKC 225-6200 Face Level Sampling Head Set, to enable positioning of the Mini-Sampler air inlet to within 10cm of the operator's mouth and nose, particularly when wearing a protective face shield.

The design air flow rate of the Mini-Sampler is 750 ml/min.

The Mini-Sampler is suitable for use with 13mm diameter filters only, such as SKC part no. 225-8050 (13 mm diameter, 5 µm pore size, MCE filter). The filter should be suitable for the intended chemical or gravimetric analysis. Consideration should also be given to the required performance of the sample pump to be used, against the likely back pressure of the loaded filter.

When carrying out gravimetric analysis the filter is pre-weighed prior to insertion into the sampler, and removed from the sampler for post-weighing. Aerosol that adheres to the surface of the sampler inlet does not form part of the sample.

The Mini-Sampler inlet components are manufactured from conductive aluminium alloy which prevents static interference on the collection of the aerosol particles.

The sampler is supplied complete with cassette sealing caps to prevent contamination or loss of the sample during transport for laboratory analysis.

Figure 1

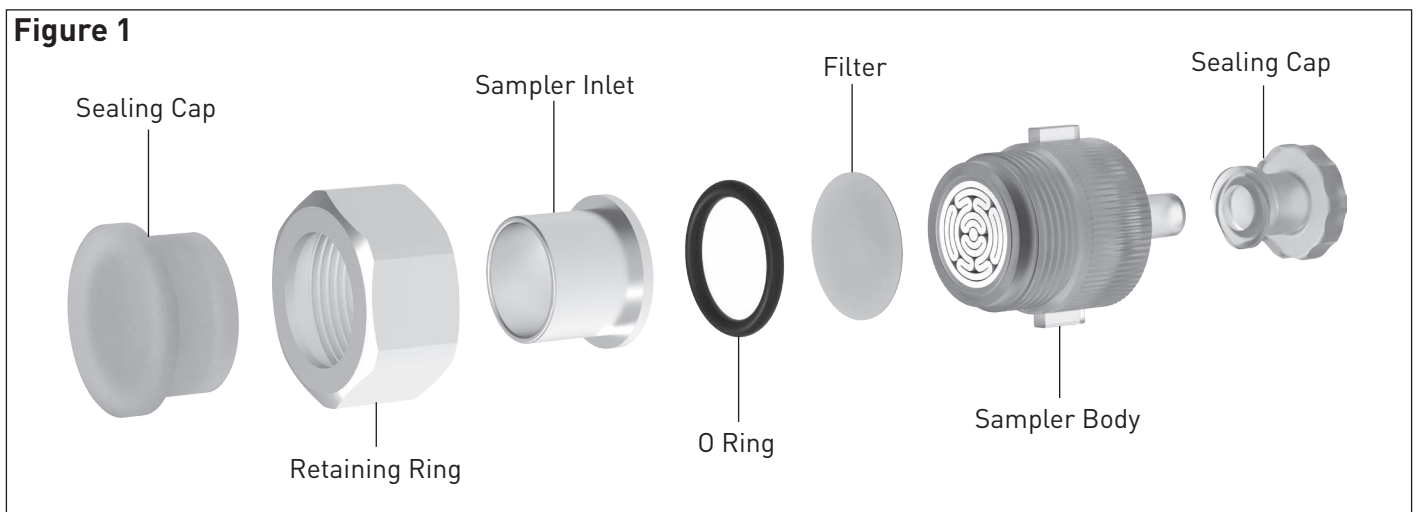

Preparing the Mini-Sampler for Use

The following instructions give basic details on how to prepare the Mini-Sampler for welding aerosol sampling according to ISO 10882-1.

Prepare the Mini-Sampler for use in a clean area, where the concentration of airborne particles is low.

Ensure that the Mini-Sampler components are cleaned of any contamination, using a detergent solution. Allow the components to dry fully before use.

Loading the filter

Refer to Figure 2 on page 2.

It is recommended to wear powder free gloves and to use tweezers when handling filters in order to prevent contamination prior to taking the sample.

Pre-weigh the filter using a suitable analytical balance if carrying out gravimetric analysis.

Fit the sampler inlet into the retaining ring and fit the O ring into the retaining ring behind the sampler inlet.

Place the filter into the retaining ring on top of the O ring. Screw the retaining ring, sampler inlet, O ring filter onto the sampler body, taking care not to dislodge the filter. Tighten carefully taking care not to damage the filter by over-tightening.

Preparing the 225-6200 Face Level Sampling Head Set

Securely fit female Luer-Lok adapter fittings to both ends of one of the positionable gooseneck tubes.

Press the male Luer-Slip fitting of the sampler body firmly

*The Mini-Sampler was developed in a research project partly funded by the Swedish Work Environment Authority, and carried out at Stockholm University, Sweden.

into one of the female Luer-Lok fittings attached to the gooseneck tube. Refer to Figure 3 on below.

Figure 2

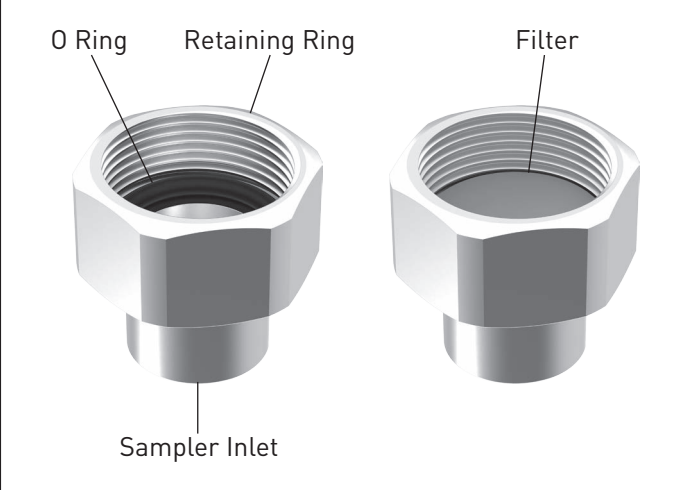
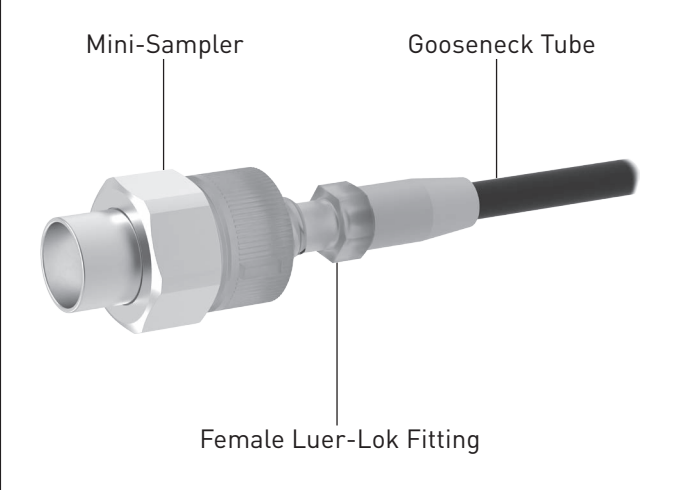

Figure 3



Flow Rate Adjustment

ISO 10882-1 specifies the use of a flowmeter with minimum accuracy of $\pm 2.5\%$ and calibration traceable to

After Sampling

At the end of the sample period check and record the sample air flow rate. Fit the sealing cap to the sampler inlet to prevent contamination of the sample.

Removing the Filter

Hold the Mini-Sampler with the inlet facing upwards. Remove the sealing cap from the sampler inlet. Unscrew the retaining ring from the sampler body. The retaining ring, sampler inlet, O ring and filter will separate from the sampler body.

Place the sampler inlet, retaining ring, O ring and filter facing upwards on a flat, clean surface. Press down on the sampler inlet and carefully lift up and remove the retaining ring, leaving the sampler inlet, O ring and filter, refer to Figure 4.

Carefully separate the filter from the O ring using tweezers and powder free gloves.

Post-weigh the filter using the same analytical balance used for pre-weighing, if carrying out gravimetric analysis.

Transportation

If further analysis is required, prepare the sample for

national standards. SKC recommend the use of the checkmate range of electronic flowmeters with accuracy of $\pm 1\%$.

Fit the male Luer-Lok fitting of the tubing assembly supplied with the Mini-Sampler to the remaining female Luer-Lok fitting on the gooseneck tube. Connect the free end of the tubing assembly to the inlet port of the sample pump.

Connect the inlet of the Mini-Sampler to the outlet port of the flow meter. SKC can supply a suitable calibration adapter, part number 225-6202 for this purpose.

Turn on the sample pump and adjust the flow rate to 750 ml/min using the calibrated flow meter. Record the sample air flow rate reading.

Turn off the sample pump and disconnect the tubing from the inlet of the Mini-Sampler. Fit the sealing cap to the inlet of the Mini-Sampler to prevent contamination of the filter prior to sampling.

Mounting the Sample Train on the Worker

Refer also to the Face Level Sampling Headset instructions.

Fit the gooseneck tube to the Sampling Head Set frame. Mount the Sampling Head Set frame onto the worker and position the inlet of the Mini-Sampler as close to the operator's mouth and nose as possible, with the inlet of the Mini-Sampler facing forwards.

Securely mount the sample pump onto the worker, ideally at the waist.

Check that all tubing connections are secure. Ensure that the tubing is suitably retained to the worker's clothing to prevent it from becoming a hazard, but also ensure that it does not impede the operator's free movement.

Final Checks

Immediately prior to sampling remove the sealing cap from the Mini-Sampler inlet.

Switch on the sample pump and record the time and date. Check and record the sample air flow rate.

Note: ISO 10882-1 requires that the sample air flow rate be checked at least at 2 hourly intervals throughout the sample period.

transportation to the laboratory by carefully re-assembling the filter into a clean Mini-Sampler and fitting the sealing caps to the sampler inlet and outlet to prevent unwanted ingress or loss of contaminant during transport.

Figure 4

