



Instructions for the fitting of rigid aluminium sampling masts to Flite and MCS series pumps, covering mast models -

- 901-213 Two piece sampling mast
 - 901-214 Four piece sampling mast
1. Unscrew and remove the inlet hosedetail from the pump.



2. Select the straight section of the mast and check that the O ring is in place in the female threaded end. Screw the straight section of the mast onto the threaded bulkhead connector on the pump. Fasten firmly hand tight, but do not apply excessive force.
3. 901-214 model only - Select the remaining two straight sections of the mast and check that the O rings are in place in the female threaded ends. Screw these sections onto the first straight section.

4. Select the bent section of the mast and check that the O ring is in place in the female threaded end. Screw the bent section of the mast onto the straight section of the mast.

5. Note - If the full 1 metre mast height is not required, use only the mast section(s) required to achieve the necessary height.

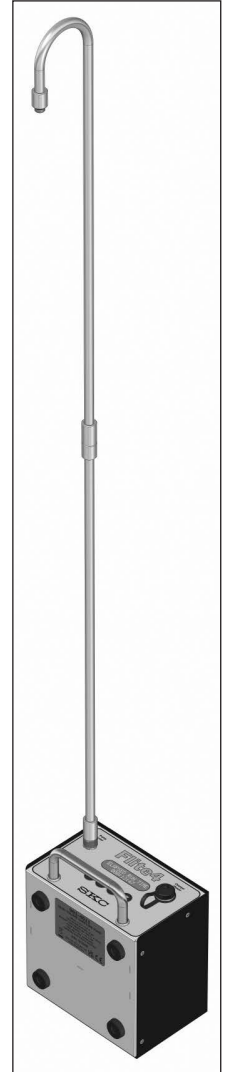

6. Prepare the cowled asbestos sampling head (225-54 or 225-54A) by unscrewing the hosetail and removing the metal bracket and plastic sealing washer.

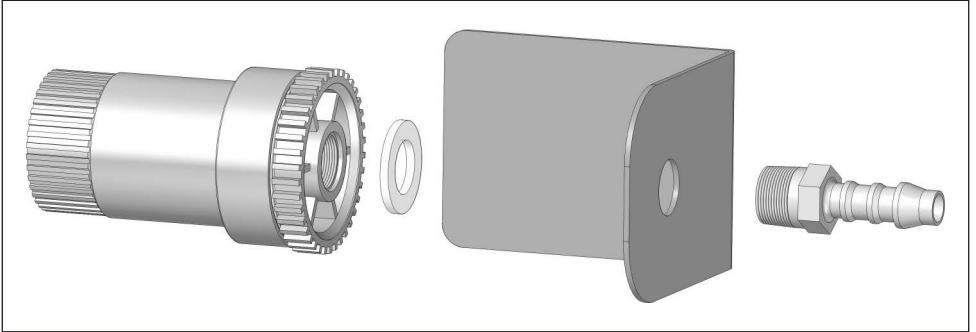

7. Screw the threaded hole on the asbestos sampling head onto the male thread at the top of the sampling mast.

