



393 series rotameter model -

- 393-002025 Flow range 20 to 250 ml/min

Introduction

The SKC 393 Series Float Style Rotameter comprises a robust perspex body and enamelled steel base with three fixed feet for stability. The air inlet is through the centre of the base providing smooth airflow and a steady reading.

A screw-in hose-tail is supplied, which screws into the top outlet of the rotameter, and enables the easy attachment of tubing to the rotameter. The hoesetail incorporates an O ring to ensure an optimum seal to the rotameter.

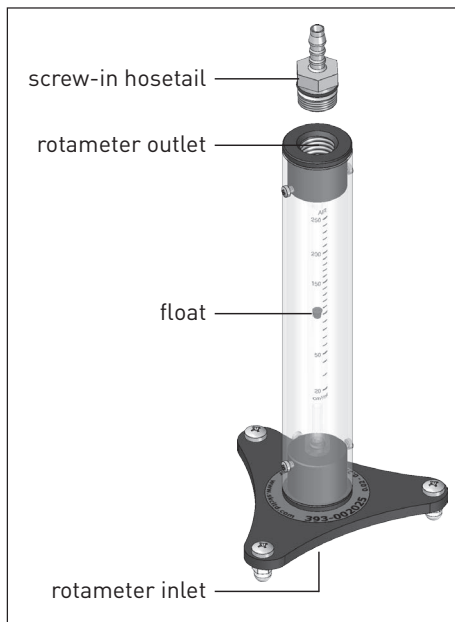

Reading the flow rate

Before taking a reading ensure that the rotameter is positioned on a level surface.

The reading is taken from the top level of the float. The operator should read the scale at eye level, not from above or below, to ensure the accuracy is maximised.

The accuracy of rotameters is impacted if the float is not steady. Ensure that the float is spinning freely and is not oscillating up and down before taking a reading.

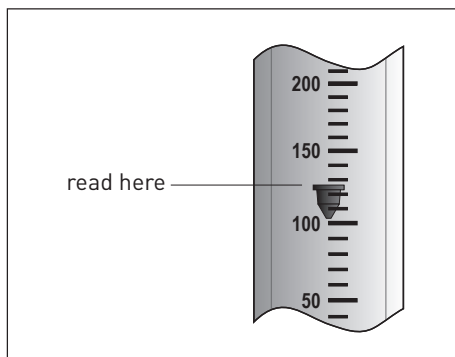

Optional accessories

717-511 - Tubing adapter for small sample tubes. Enables leak free connection of small diameter sorbent tubes to the rotameter.

Accuracy specification

The 393-002025 model rotameter has the following accuracy specification - $\pm 2.5\%$ of full scale

Accuracy values expressed as percentage of reading for the major scale flow rates for the 393-002025 model rotameter are given in the table below -

Flow Rate (ml/min)	Accuracy (% of reading)
250	2.50
200	3.12
150	4.17
100	6.25
50	12.50
20	31.25

Ambient temperature and barometric pressure correction

The 393 series rotameters are standardised to 20°C and 1atm (1013.25mbar). The ambient temperature and barometric pressure when using the rotameter will vary from these values, so the indicated rotameter reading should be corrected to the ambient conditions as follows -

$$Q_{\text{corrected}} = Q_{\text{indicated}} \times \sqrt{\frac{1013.25}{p_{\text{barometric}}} \times \frac{T_{\text{ambient}}}{293.15}}$$

where:

$p_{\text{barometric}}$ is the barometric pressure in mbar.

T_{ambient} is the ambient temperature in Kelvin ($^{\circ}\text{C} + 273.15$).