

# step by step guide to air sampling

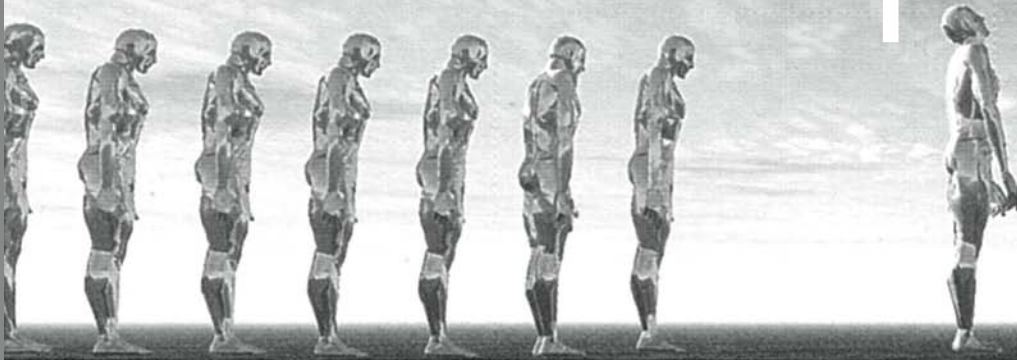

[www.skcltd.com](http://www.skcltd.com)

## an introduction to the basics



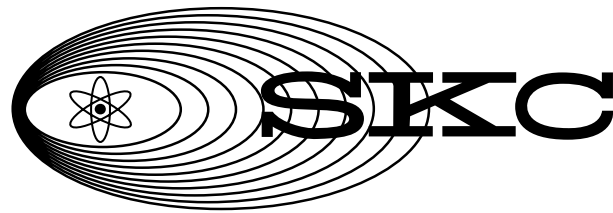

The Worlds Finest Air Sampling Products

Contents:

Introduction.....3

What is Air Sampling? .....4

Sampling Methods .....5

Types of Contaminant .....6

Basic Formulae / Definitions.....7/8

The Dust Diagram .....9

ISO/CEN Criteria for Dust .....10

mg/m<sup>3</sup> and ppm.....11

Calibration.....12

Dust Sampling - Inhalable .....13

Dust Sampling - Respirable.....14/15

Gas and Vapour Sampling.....16

Sorbents .....17

The Sample "Train".....18

Check List .....18



## A Helping Hand From the Experts



**SUPPORT, KNOWLEDGE, CHOICE**

This book is designed as an introduction to the basic principles of Air Sampling methods. The advice in this manual deals with the setting up of equipment only. Advice notes can be obtained from the HSE ([www.hse.gov.uk](http://www.hse.gov.uk)) and these will give you a good understanding of the approach you should take to sampling in your particular industry.

As an expert in the field of air sampling, SKC believe in supporting customers every step of the way, so in addition to the Step By Step guides there is a range of training seminars available to help you get the best from your sampling equipment.

If you are new to air sampling, our one day seminar '**A Practical Course in Air Sampling**' will give you the help you need to get started.

The course includes both theoretical and practical sessions in the use of air sampling equipment. An experienced practitioner will offer valuable input on sampling strategy and will assist with instrument configuration and calibration. You will soon have everything you need to formulate a professional monitoring programme.

Contact the SKC customer service centre today for details on courses and available dates:

**Tel:01258 480188**  
**Email: [info@skcltd.com](mailto:info@skcltd.com)**



# What is Air Sampling?

Put simply, air sampling is capturing the contaminant from a known volume of air and measuring the result as a concentration.

The air is taken through a filter medium (normally a paper for solid contaminants and a sorbent for gases). The volume of air is measured against the amount of contaminant captured. This gives the concentration, which is expressed either as milligrams per cubic metre ( $\text{mg}/\text{m}^3$ ) or parts per million (ppm).

The volume of air is calculated by multiplying the flow rate through the filter medium by the time in minutes. Calibration is important and should be carried out before and after each sample is taken.

## How is it Done?

There are many different methods of taking air samples, but by far the most widely used and preferred is to connect a battery operated pump to a filter medium. The pump should be capable of drawing air through the filter at a constant rate for a time in excess of 8 hours, even in adverse conditions such as extreme cold.

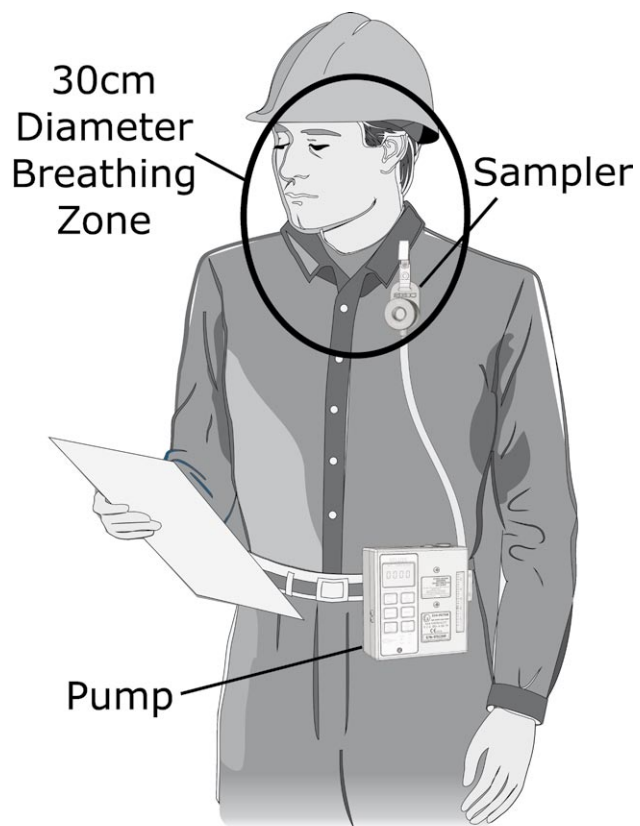

This criteria is based around the recommendations that samples should be taken on a personal basis for an 8 hour Time Weighted Average (TWA). Other types of sampling, notably the Short Term Exposure Limit (STEL) present no problems for the pump sampler.

It is also worth remembering that a sample by definition is a very small part of the whole. For example: taking one or two parts from a batch of one hundred and checking them does not necessarily mean that the other ninety eight parts will be the same. Do not assume that a result from your air sample is exactly what is in the atmosphere all the time.

# Sampling Methods

## Filter Sampling Inhalable (Total) Dust

Air is drawn through a filter paper, which traps the solid particulate e.g. dust, aerosols & fibres. Gravimetric analysis is usually used to measure results (i.e. by measuring the weight gain of the filter). Further analysis can be carried out on the filter to identify the specific chemicals captured.



## Filter Sampling Respirable (Alternative Method)

The Cyclone Sampler uses a filter contained in a cassette, which separates out the respirable fraction of dust in the sample.

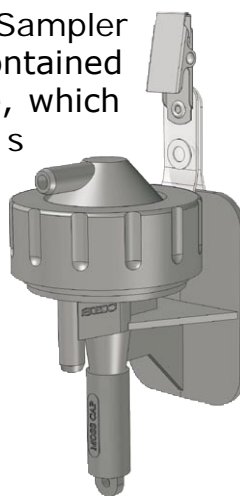

## Bag Sampling

Particularly suitable for "grab" or Short Term Samples (STS), the air is passed through the pump into a special plastic bag. Alternative methods of filling a bag without passing air through a pump can also be used. The bag, containing a relatively large volume of sampled atmosphere is then taken to the laboratory for analysis.



## Sampling Respirable Dust

The IOM\* Sampler with a foam plug placed in the cassette inlet is capable of sampling respirable dust. The specific foam separates the respirable fraction, which is collected on the filter, from other particle sizes.



## Sorbent Sampling

Sorbents are normally contained in a small glass tube with sealed ends. Air is drawn through the sorbent, which captures molecules of the gas or vapour to be sampled. The trapped contaminants are released using solvent washing or heat to a gas chromatograph (GC) for analysis. One of the best known sorbents is charcoal.

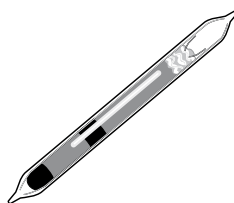

## Impinger / Bubble Sampling

Air drawn into the impinger is forced through a nozzle, which is covered by a liquid such as high purity water. The pollutant dissolves in the liquid and is subsequently analysed, usually by colorimetric techniques.

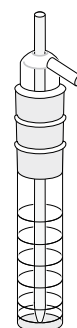

## Other Methods

There are alternative samplers to those shown above, including combinations of tube & filter; impinger and special samplers for specific uses such as chemically impregnated filters and passive badges. Details of all of these methods can be found in the SKC catalogue. To order your copy contact our customer services team on 01258 480188.

\*Manufactured under license from the Institute of Occupational Medicine TM 2043339E

# Types of Contaminant

There are three types of contaminant according to their physical properties:

- Particulates
- Gases
- Vapours

Particulates can be further subdivided into five types:

- Aerosols
- Dusts
- Fumes
- Smokes
- Mists

Contaminant definitions:

- **Aerosol** Dispersion in air of solid particles of microscopic size.
- **Dust** Solid particulate capable of temporary suspension in air. Dusts are usually derived from larger masses through the application of physical force.
- **Fume** Solid particles produced by condensation from the gaseous phase. Fumes are usually derived from the heating of a solid to its melting point and the subsequent cooling of the gas produced.
- **Smoke** Particles resulting from the incomplete combustion of organic matter consisting predominantly of carbon and oxides of carbon.
- **Mist** Dispersion in air of liquid droplets usually large enough to be seen by the naked eye.
- **Vapour** Gaseous phase of a substance that usually exists as a liquid or solid at normal room temperature and pressure.
- **Gas** A substance which does not normally exist as a liquid or solid at normal room temperature and pressure.

## Basic Formulae

### Conversion of parts per million (ppm) to milligrams per cubic metre (mg/m<sup>3</sup>)

$$\text{ppm} \times \frac{\text{molecular weight}^*}{24}$$

$$(\text{mg} = \text{g}/1000)$$

\*If the molecular weight is not known it can be worked out using a periodic table.

### Calculation of volume of air sampled

Sample flow rate in litre/min x sample time in minutes, eg:

2 litres per minute (l/min) x 8 hours - giving 2 x 8 x 60 = 960 litres.  
As there are 1000 litres per cubic metre (m<sup>3</sup>) - divide the result by 1000

$$960 \text{ litres} = \frac{960}{1000} = 0.96 \text{ m}^3$$

### Calculation of time weighted average (TWA)

To work out an 8 hour TWA from more than one sample within any 24 hour period:

$$\frac{(C1 \times T1) + (C2 \times T2) + \dots + (Cn \times Tn)}{8}$$

where C is the occupational exposure and T is the time for that exposure, eg:

An operator is exposed to 0.12mg/m<sup>3</sup> for 7 hours and 20 minutes.  
The 8 hour TWA is therefore 7hrs 20 minutes @ 0.12mg/m<sup>3</sup> (C1 x T1)  
plus 40 minutes at 0.00mg/m<sup>3</sup> (C2 x T2). The calculation is as follows:

$$\frac{(0.12 \times 7.33) + (0 \times 0.67)}{8}$$
$$= 0.11 \text{ mg/m}^3$$

**Note:** 7h 20 minutes = 7.33 hours  
40 minutes = 0.67 hours

# Definitions

## Maximum Exposure Limit (MEL)

An MEL is the maximum concentration of airborne substance to which employees may be exposed by inhalation averaged over a regulatory required reference period and must not be exceeded.

## Occupational Exposure Standards (OES)

The OES limits are referred to as Occupational Exposure Limits (OEL).

An OEL is the concentration of an airborne substance, averaged over a reference period at which, according to current knowledge, there is no evidence that it is likely to be injurious to employees if they are exposed by inhalation day after day to that concentration. These were replaced on 6th April 2005 by WELs (refer to EH40/2005).

## Workplace Exposure Limits (WELs)

WELs are occupational exposure limits (OELs) set under COSHH<sup>3</sup>, in order to help protect the health of workers. WELs came into force from 6th April 2005. WELs are concentrations of hazardous substances in the air, averaged over a specified period of time referred to as a time weighted average (TWA). Two time periods are used: Long term (8 hours) and short term (15 minutes). Short term exposure limits (STELs) are set to help prevent effects, such as eye irritation, which may occur following exposure for a few minutes.

## AIR SAMPLE

1. **Amount** collected
2. **Flow** of air through filter
3. **Time** run

Flow x Time = Volume through filter in litres or cubic metres

Volume and Amount gives  
CONCENTRATION in  $\text{mg}/\text{m}^3$   
or  
parts per million (ppm)

An air sample requires three basic measurements: amount of pollutant collected; flow of air through the medium and the run time in minutes.

### Personal Sampling

All exposure limits are based on a personal sample

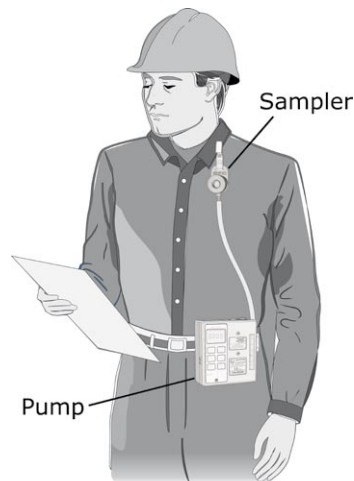

All exposure limits are based on personal exposure. At this time there are NO limits for background or static samples, however, some people do take static samples for their own information to get an idea of general levels of contamination. If it is considered that a person creates their own airborne hazard as they work and that their face is normally in close proximity to that hazard, it is clear to see why personal sampling is the accepted way of measuring contaminants.

# The Dust Diagram (continued)

## ISO/CEN HEALTH RELATED SAMPLING CONVENTION FOR AEROSOL (Refer to EN 481)

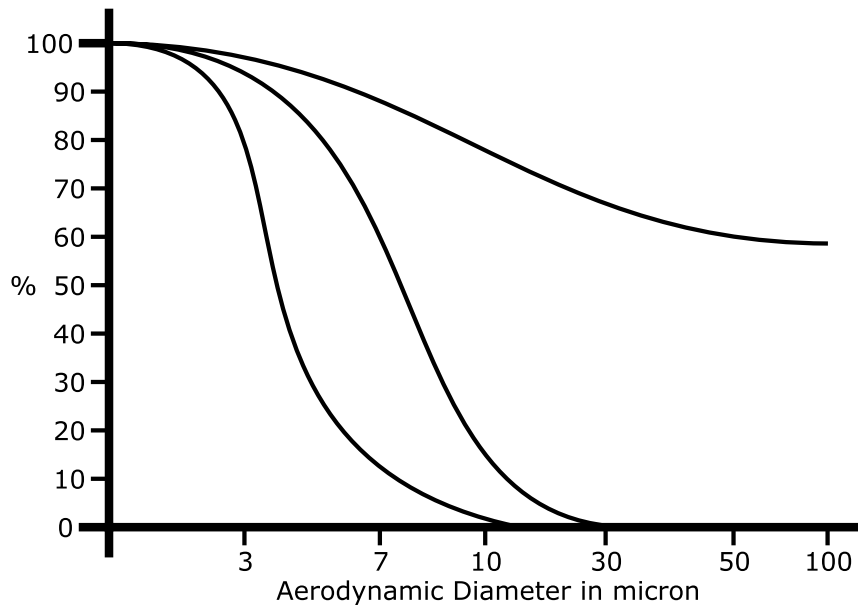

Dust, or more correctly aerosol, is split into three size ranges, which have different effects on the respiratory system of a human being. The smaller the particle the deeper into the lungs it can penetrate where it could settle onto the lining and cause respiratory illness (a well known problem caused by respirable dust is Silicosis in the coal mining industry). Historically respirable dust has demanded the most attention but in the last few years particles of larger sizes have been investigated for their effect on the upper respiratory tract (throat, nose and mouth). Inhalable and thoracic dust are a relatively recent addition. It is important to note that inhalable dust contains both thoracics and respirables, in the same way that thoracic dust contains respirable particles.

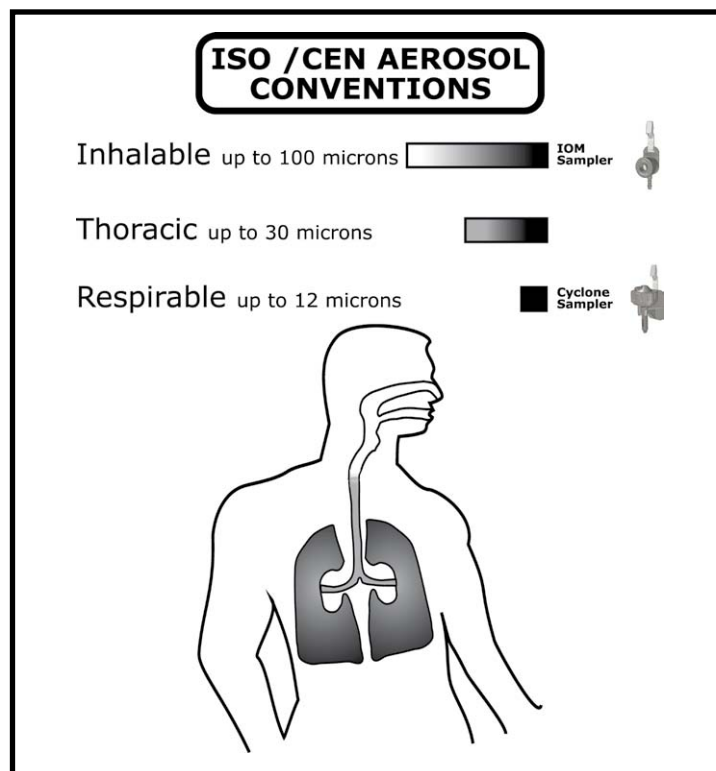

### 1 milligram per cubic metre (1mg/m<sup>3</sup>)

is about the same as one teaspoon of flour spread over the area of a football field to a height of one metre



**Teaspoon**

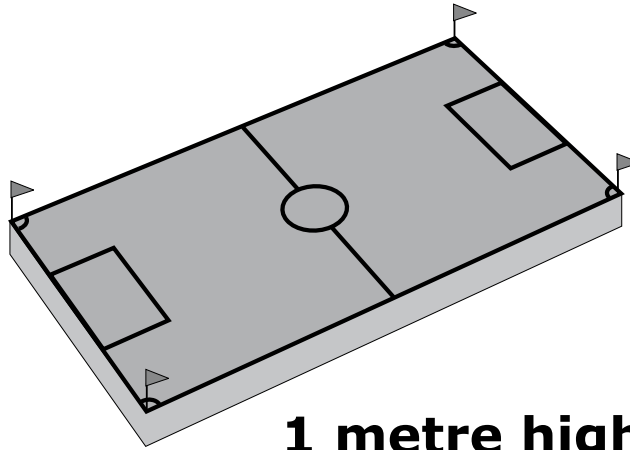

**1 metre high**

### 1 part per million (1ppm)

is about the same as the contents of a part balloon in the volume of 50 three bedroom houses



**X 1**

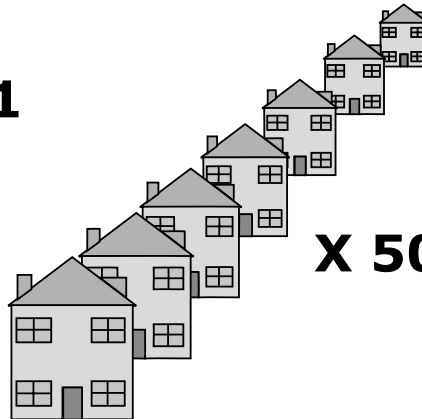

**X 50**

Concentrations are expressed as mg/m<sup>3</sup> for solids or parts per million (ppm) for gases. For example 1 ppm of a gas means that 1 unit of the gas is present for every 1 million units of air. It is not always easy to picture what 1ppm actually means, so the diagram above may help to get some idea of the scale. The analogies shown are approximate but do give a reasonable representation of concentration.

If it is considered that the exposure limit for any kind of dust is 10mg/m<sup>3</sup> the comparison of 1 teaspoon of dust over a football field shows how little this really is.

There is a move to express concentrations of gas as mg/m<sup>3</sup> so we have also included a conversion formula in the BASIC FORMULAE section on page 7 of this guide.

# Calibration

Calibration of the flow through the sampling system is important and should be checked before AND after every sample is taken. Broadly speaking there are two different levels of flow commonly used for personal sampling systems. For dust the flow is often set at around 2 litres per minute and for gases and vapours between 10 and 200 ml per minute.

The usual method of flow measurement (calibration) for the higher flows is achieved using a rotameter (variable area flowmeter). Both 2 litres per minute for inhalable dust using the IOM sampler and 2.2 litres per minute for respirable dust using the cyclone sampler can be set using this type of device. The flow is read from the float inside the graduated glass tube.

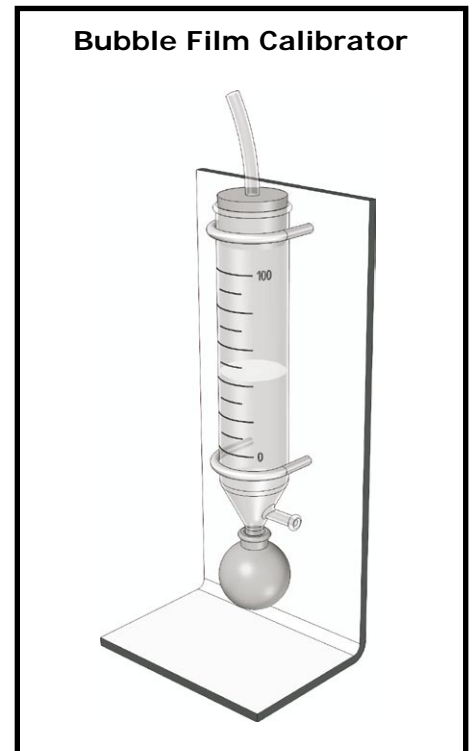
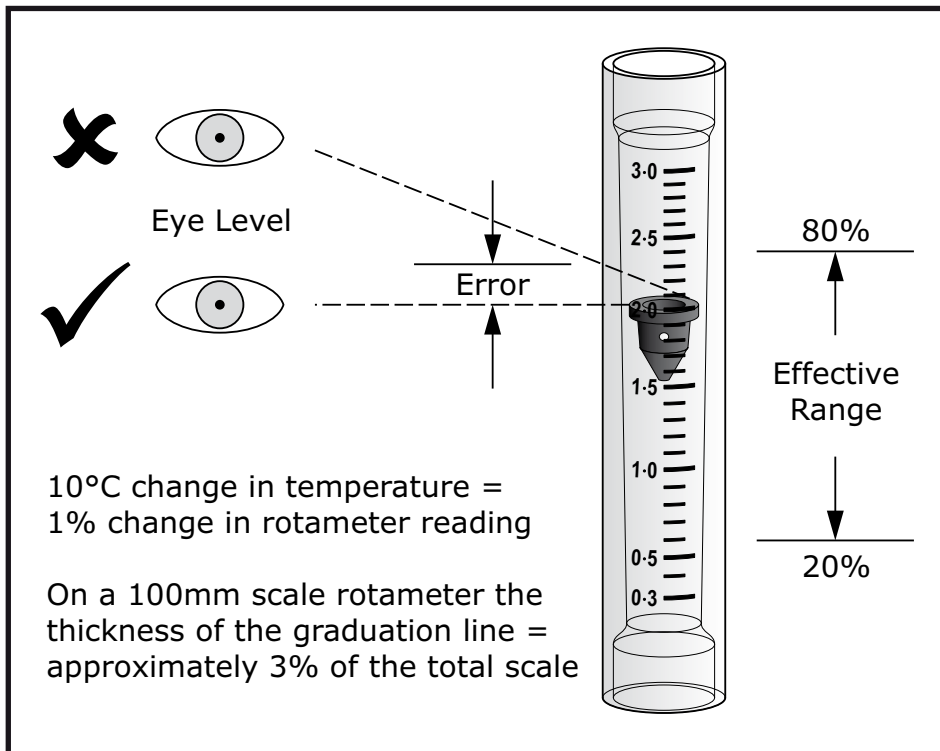

For the lower flows of between 10-200 ml per minute normally required for gases, a bubble film calibrator is suitable. This unit has high accuracy and low back pressure with superior resolution compared with the rotameter mentioned above. The flow is calculated by timing a bubble between two graduation marks on a glass tube with a stopwatch.

A third alternative is to use an electronic calibrator, such as the Defender primary calibrator, which operates on the same principal as the bubble film calibrator but it electronically detects and times a passing piston. An LCD screen shows the flow measured.

This instrument has a much larger range than the manually timed bubble film or rotameter devices and typically covers from 50-5000 ml/min. Its accuracy is also better than the manually timed version across the entire range.



## Dust Sampling - Inhalable

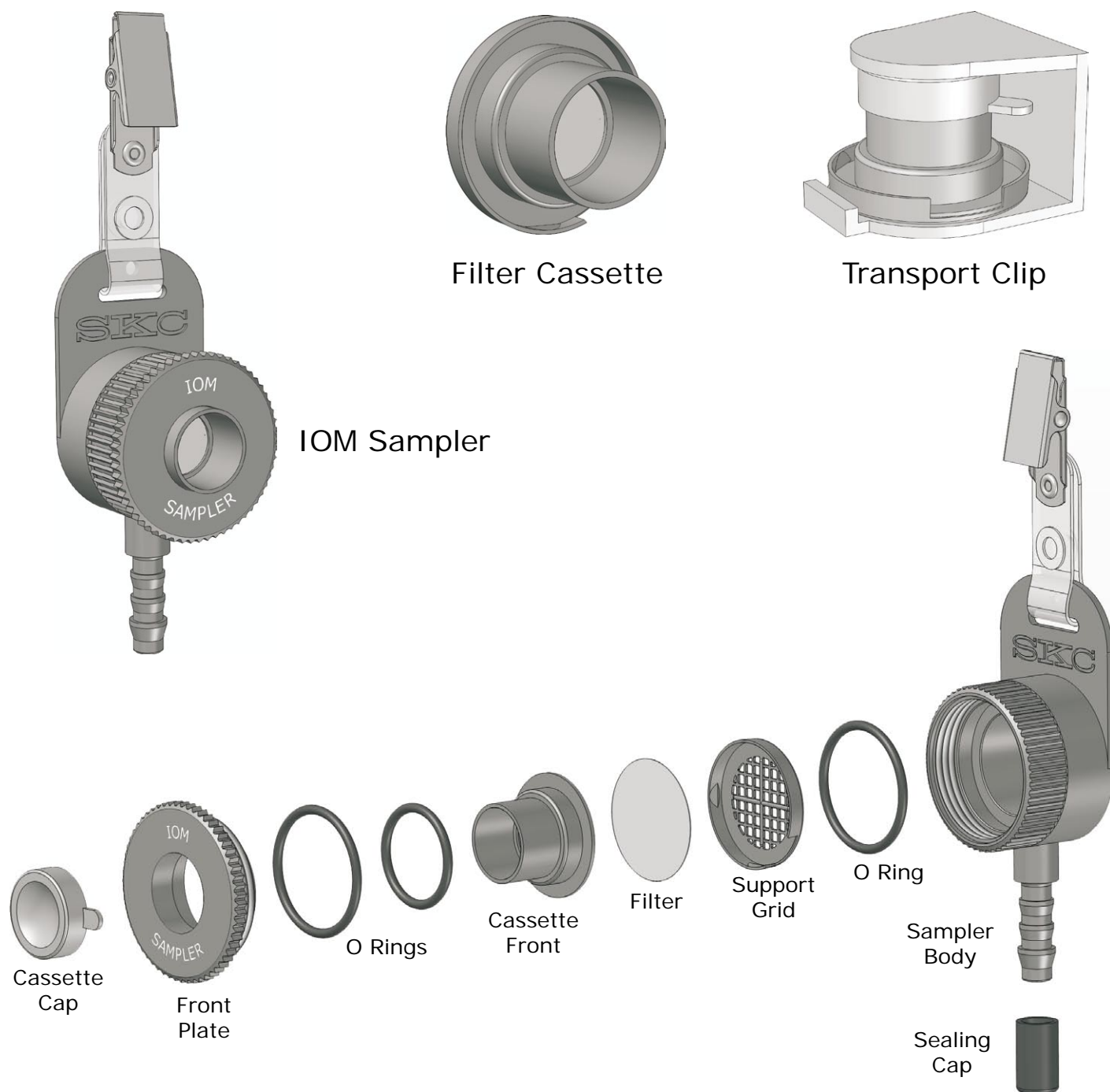

For inhalable dust the IOM Sampler is used. The filter is placed between the cassette front and the support grid, which clip together to make a one piece unit. The **whole cassette assembly** is then pre-weighed before a sample is taken. After completion of the sample the **whole cassette assembly** is then post-weighed.

The IOM Sampler retains all the particulate drawn into it using this filter/cassette combination, and eliminates problems of wall loss, and the resulting potential under sampling, as experienced with other types of sampling device.

## Dust Sampling - Inhalable & Respirable

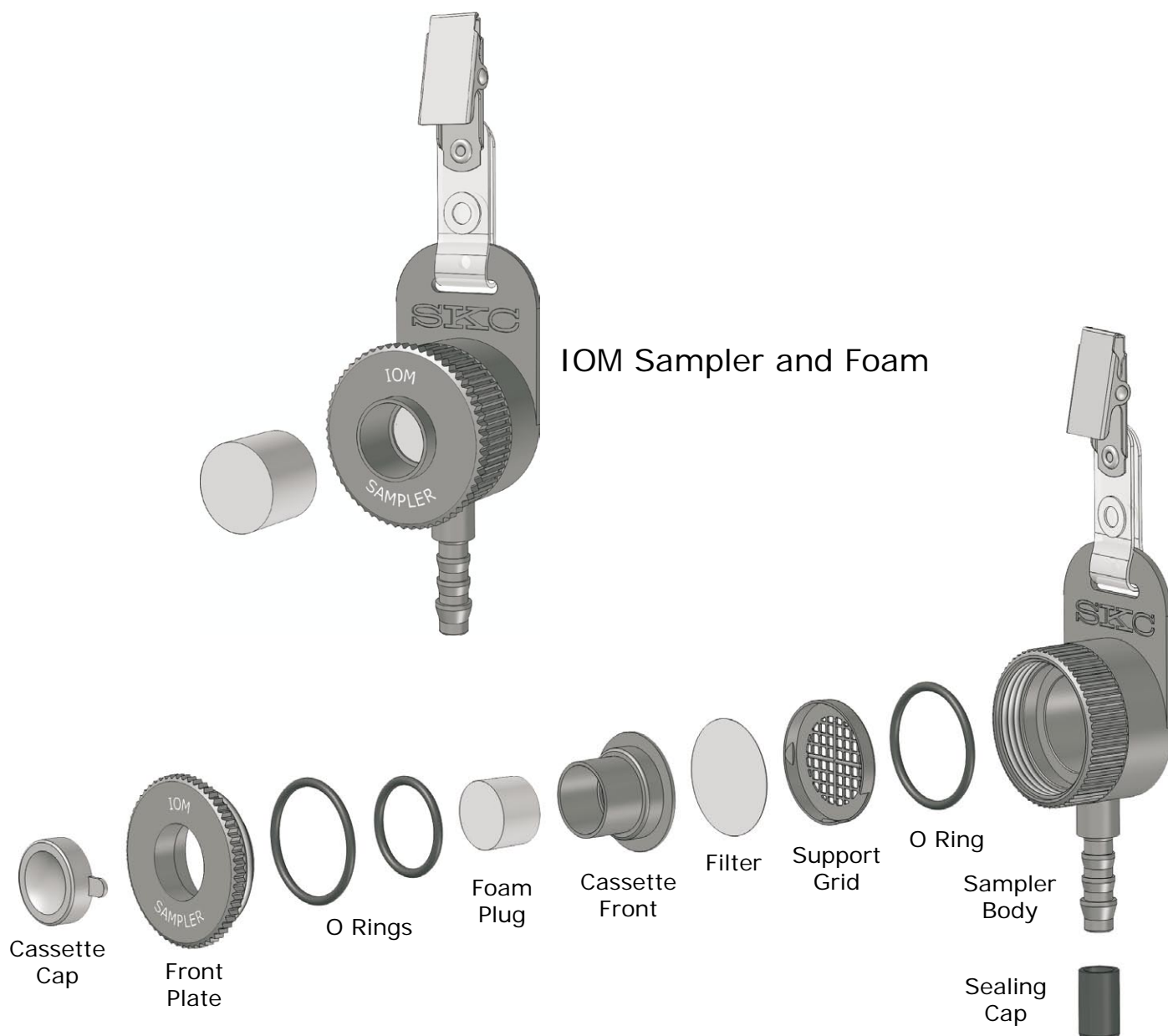

The IOM Sampler can be used for inhalable and respirable dust sampling by inserting an appropriate foam plug into the entry (front part) of the cassette. The pores in the foam allow the particles to be collected to pass through onto the filter, while trapping the unwanted (larger) particles. The plugs are certified and manufactured in a range of densities depending on the type of dust contamination to be sampled.

# Dust Sampling - Inhalable & Respirable (continued)

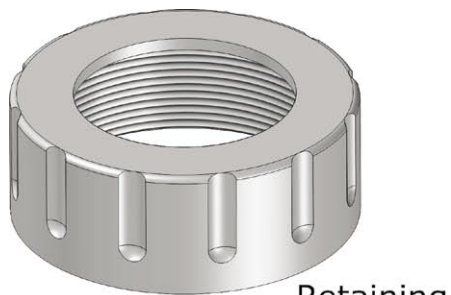

Retaining Ring

Air Outlet



Sampler Top



Filter Cassette

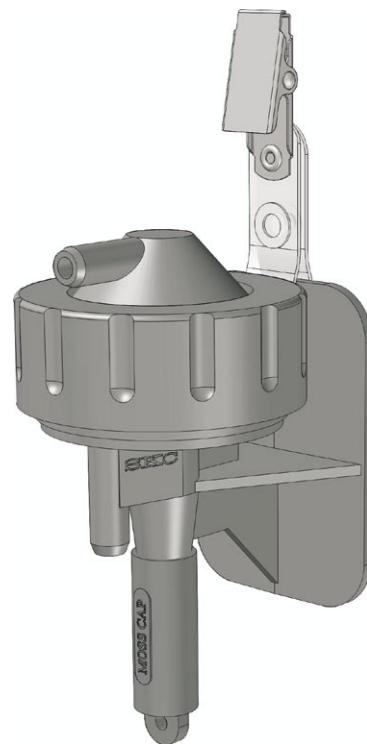

Cyclone Sampler



Air Inlet

Sampler Body



Grit Pot

Filter Transport Cassette

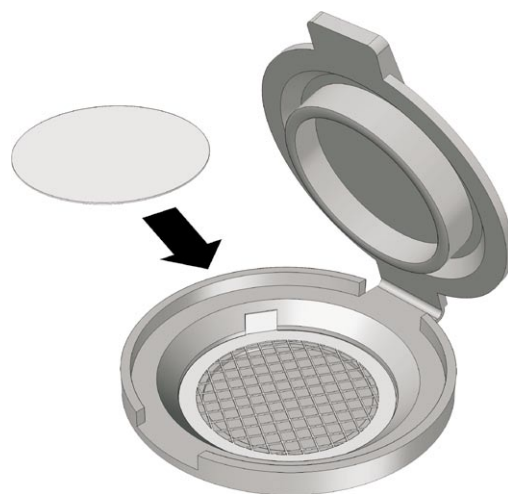

For respirable dust a Cyclone Sampler can be used, which separates the respirable fraction (approximately 12 micron and below) of the particulate from the atmosphere drawn through it. The Cyclone Sampler is designed so that smaller particles are carried onto the filter paper inside the cassette and larger unwanted particles drop into the grit pot. Unlike the IOM Sampler cassette/filter paper combination, the Cyclone version should not be weighed as a unit. Only the filter paper is weighed pre and post sampling. This instrument must be run at a flow of **2.2 litres per minute** to give the correct performance.

## Gas & Vapour Sampling

To sample for gases or vapours, especially for longer periods such as 8 hour TWA, the use of sorbent tubes is a widely accepted method.

A Sorbent is like a sponge, which soaks up the molecules of the material being sampled (which can subsequently be extracted and analysed). Activated charcoal is the most commonly used material but it can not adsorb every substance, which is why other materials such as Silica Gel and Tenax are often used.

Once the pollutant has been trapped by a sorbent tube it then needs to be removed for analysis. This is achieved using either a solvent wash or heat, which drives the collected chemicals off the sorbent and into an analytical instrument such as a Gas Chromatograph.

Most tubes have two beds of sorbent in them, the smallest of which (usually situated nearest the pump) is known as the backup. Analysis of the backup sorbent reveals whether **breakthrough** has occurred (see figure below).

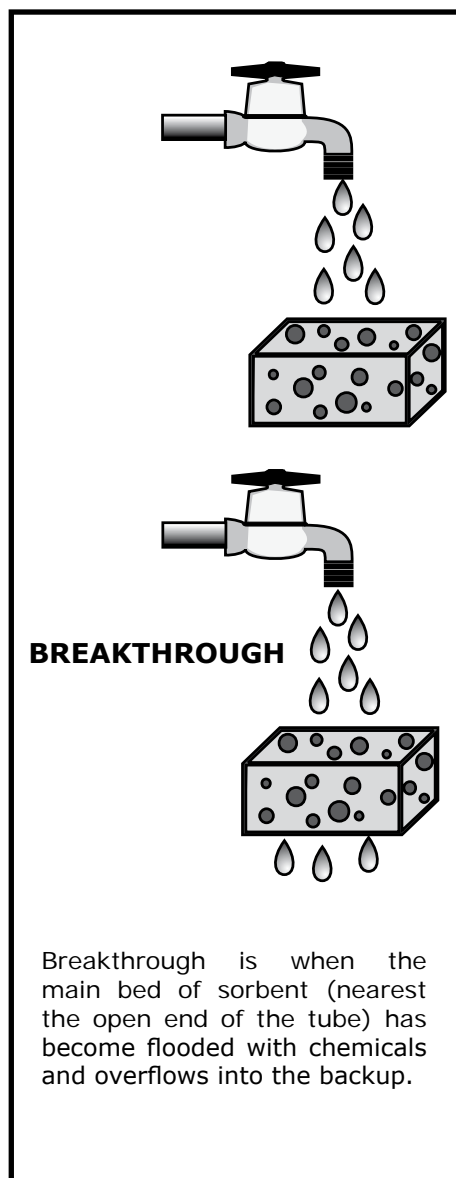

Breakthrough is when the main bed of sorbent (nearest the open end of the tube) has become flooded with chemicals and overflows into the backup.

Gas is sampled in one of the two following ways using a sorbent:

1. Active sampling using pumps and tubes.
2. Passive (or Diffusive) sampling using Badges.

There are many different types of sorbents and an even larger number of different sorbent tubes.

Each tube is designed and validated for a specific substance. Sorbent tubes vary in size from the Standard Charcoal Tube (6 x 70mm) to "Jumbo Tubes" (10mm x 110mm) and they have different separators between the sorbent beds.

Usually there will be an arrow on the casing indicating the correct way to mount the tube. If an arrow is not present, as a general rule the end with the **smallest** air space should be towards the pump. Always ensure that the tube is **vertical** when sampling.

# Sorbents

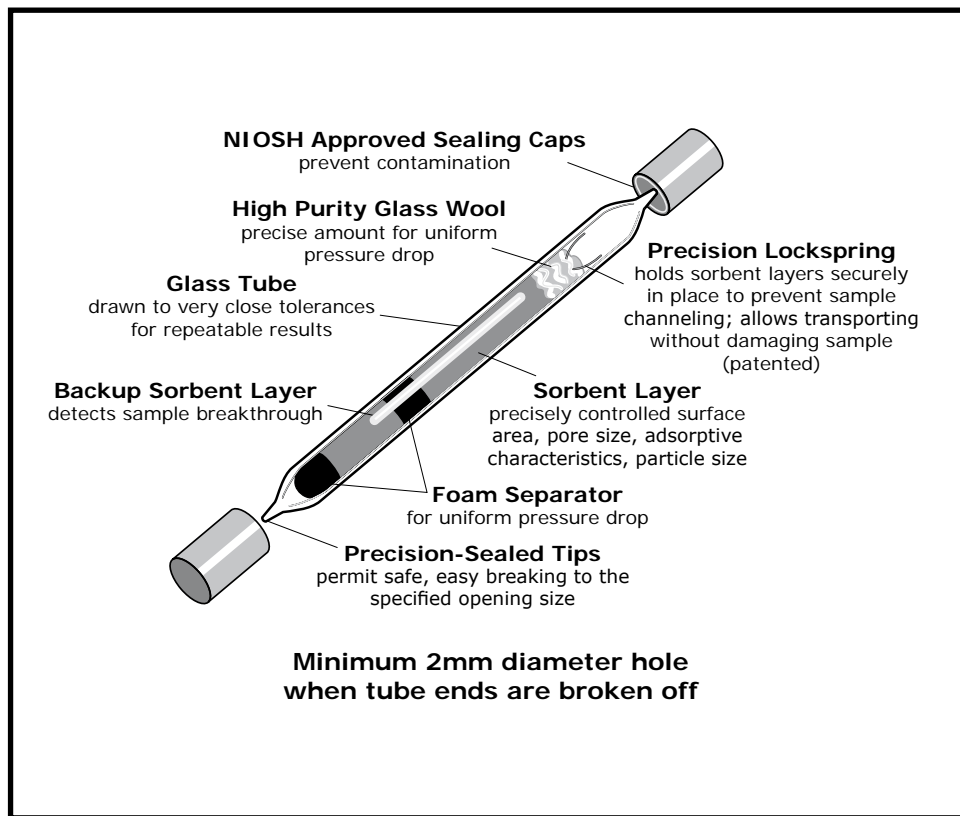

Production of sorbent tubes is carried out under strict conditions and when preparing to take a sample, care must be taken to ensure that no contaminant is present in the vicinity as this may contaminate the sorbent during calibration and cause an inaccurate reading. When breaking the ends off the tube a minimum 2mm diameter hole must be made. Always check the suitability of the sorbent for the relevant compound before use.

To recap:

- Check suitability of the sorbent.
- Make sure there are no contaminants during preparation.
- When breaking the ends off the tube there must be a minimum 2mm diameter hole.
- Ensure that the tube is inserted the correct way round.
- Always ensure that the tube is **vertical** during sampling.

## The Sample "Train"

The sample "train" is the name given to the combination of a pump, flexible tube and sampling device when connected together. It does not matter what kind of sampling device is attached to the pump as there are no specific terms for individual setups.

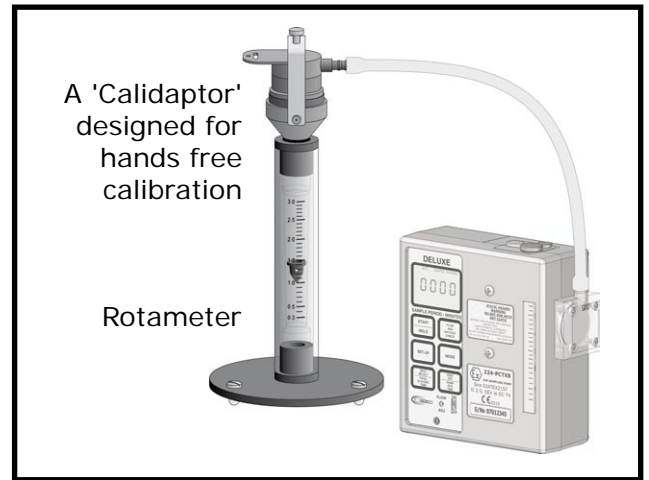
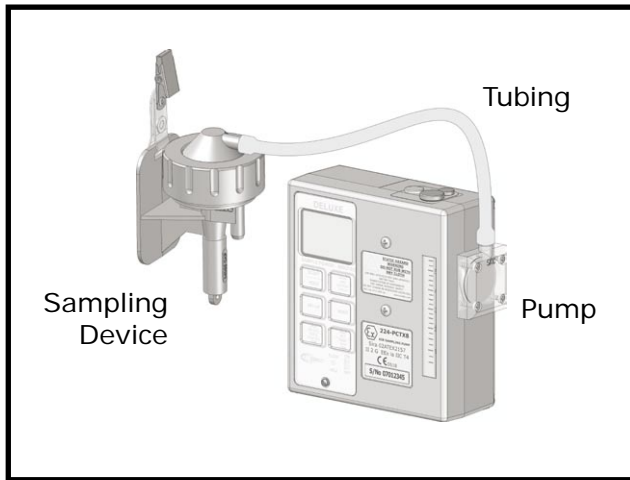

The above figures give examples of sampling trains. Additionally the figure on the right illustrates the sample train during the process of calibration.

## Check List

### Points to check with your sampling train

- Ensure the pump is fully charged.
- Treat the filter media with care.
- Calibrate in a clean area to avoid contamination of the filter media.
- Ensure the flow rate is set at the correct level required for the sampling device or methodology.
- Ensure that all connections are leakproof and secure.
- Mount the sampler in the "breathing zone".
- Ensure the flexible tube is not left to hang free.
- Note the start and finish time.

## Need Extra Help?

You should now have all the information you need to get started but if you're still unsure how to proceed contact the SKC customer service department to book into one of the regular air sampling courses.

### Questions for a Sampling Protocol

- **WHO** are the most susceptible?
- **WHERE** are the most susceptible?
- **WHEN** are they most likely to be exposed?
- **WHAT** are we looking for?
- **HOW** do we do it?

### Notes

Step by Step  
Solutions for  
Air Sampling...



SKC Limited  
11 Sunrise Park  
Higher Shaftesbury Road  
Blandford  
Dorset  
DT11 8ST  
United Kingdom

tel: 44 (0) 1258 480188  
fax: 44 (0) 1258 450968  
email: [info@skcltd.com](mailto:info@skcltd.com)



**Support, Knowledge, Choice**